

Thermostatic heads

Art. 129 – 130 – 130cr - 131



100% MADE IN ITALY 

Function To be correctly used, all thermostatic valves should be equipped with a thermostatic control like Pintossi + C thermostatic head art. 129 – 130 – 130cr – 131.

The main function of the thermostatic head is to automatically adjust the fluid supply flow rate of a radiator. This operation is done by the expansion or reduction of the **liquid sensor** contained inside the actuator, depending on the measured room temperature.

In this way, the sensitive element has the functions of a servo control which, by acting on the valve head, determines the position of the shutter and consequently the quantity of water in the radiator necessary to keep the pre-set room temperature as constant as possible.

On each number marked on the thermostatic controller corresponds a precise value of a fixed room temperature. Designed and built for **low thermal inertia functioning** together with Pintossi + C thermostatic valves.

Standard version in white color. Chromed plated version art.130cr is available to be used on designer radiator.

Product range

Art. 129	∅ 30x1,5
Art. 130	∅ 26x1,5 
Art. 130cr	∅ 26x1,5
Art. 131	∅ 26x1,5

Technical specifications

Max fluid temp.:	100°C
Min. room temp.:	-5°C
Max. room temp.:	50°C
Max. fluid pressure:	10 bar
Max differential pressure:	1 bar
Temp. range:	6°C – 30°C

Antifreeze temp:	6°C
Hysteresis:	0.3K
Shutter authorities:	0.92
Response time:	25 min
Influence of differential pressure:	0.7K
Influence of water temperature:	0.8K
Control accuracy:	0.6K
Capillary tube length art.131:	2m
Nominal flow rates in combination with valves:	straight version: 3/8-1/2 180 kg/h angle version: 3/8-1/2 170 kg/h

Materials

Body:	ABS
Ring:	Stainless steel
Sensor:	Liquid

Dimensions

ART.	Ø	A	B	C	KEYMARK
129	30x1,5	27,5	49	77	
130	26x1,5	27,5	49	77	
130cr	26x1,5	27,5	49	77	
131	26x1,5	27,5	49	77	

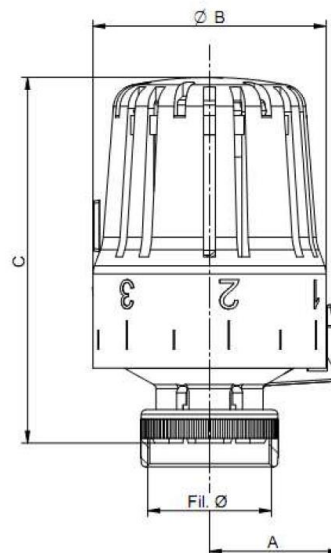

Control adjustment scale

On each number marked on the thermostatic controller corresponds a precise value of fixed room temperature, as per the following table:

Scale	0	*	1	2	3	4	5
Temperature °C	0°C	6°C	11°C	16°C	20°C	25°C	30°C

Assembling of thermostatic head

- 1- Remove the handwheel or protective cap from the thermostatic radiator valve.
- 2- Adjust the thermostatic head to the maximum opening position.
- 3- Apply the thermostatic control on the valve by matching hexagons, manually tighten the ring nut on the body. The tightening must be easy; otherwise do not use excessive force and repeat operation 2.

- 4- Turn the handle until the desired setting and move the clamps fittings into the slots on the right and left of indicator: left clamp limits the minimum temperature and right clamp the maximum one.

Tamper-proof protection

The thermostatic head can be protected against tampering and theft by mounting Pintossi + C protective cover art.132. The cover can be locked using special screws that can be installed and uninstalled only using Pintossi + C specific spanner art.133..



Use tips

To obtain an optimal functioning of the thermostatic valves where the thermostatic head has been installed, it's important to evaluate the conditions of the actual installation.

The liquid sensor should be installed in a position where is touched by the room convective motions of the air, in order to detect the effective average room temperature.

For this reason, it's recommended to install the thermostatic head where these motions can't be restricted by obstacles like: radiators coverall, wall niche, curtains, etc.



For all the situations where the radiators have been installed in the above-mentioned situations, the best solution is to use Pintossi + C thermostatic actuator with remote sensor art.131

Design radiators

In the situation where the thermostatic head has to be installed on designer radiators or fashion environments, the top solution is to use Pintossi + C chromed thermostatic head art.130cr.

Summer period

During summer time is recommended to maintain the thermostatic head on position 5 in order to avoid an excessive tight from the control on the thermostatic valve stem.

Accessories

In order to use 30x1,5 thermostatic head on Pintossi + C thermostatic radiator valves, it can be used a specific item art.328 that can be used as adaptor between Pintossi thread and the thermostatic head with 30x1,5 thread.

Certification

The thermostatic head Art. 130 in combination with valves Art. 100-101-104-105-110-111-114-115 in sizes 3/8 and 1/2, is approved in compliance with the requirements of the UNI EN 215 KEYMARK standard.